

LT8311XE-Q ---Product Brief

USB2.0 Extender

1. Features

- USB2.0 signal extension up to 10m over USB cable for one chip application
- USB2.0 signal extension up to 40m over Cat6 cable for two chip application
- Support USB2.0 high speed, full speed and low speed signal transferring
- I2c mode equalization control for different length cable
- 2 lines data transferring
- Single 3.3V power supply
- QFN16 4mmx 4mm RoHS package
- -40°C to 85°C operating temperature range
- ESD 2kV HBM

2. Description

LT8311XE-Q is a low cost high performance USB extender that provides signal transferring extension over USB cable or net cable. Compliant with USB2.0 specification, LT8311XE-Q supports USB2.0, USB1.1 and USB1.0 device connection. The maximum extension length can be up to 40m from the location of USB hub/host. It eliminates the 5m distance limitation of USB2.0 Specification. There are only 2 lines used for data transferring between two LT8311XE-Q chips.

3. Application

- PC Motherboard
- Servers and workstation
- KVM system
- Data storage system
- Car system

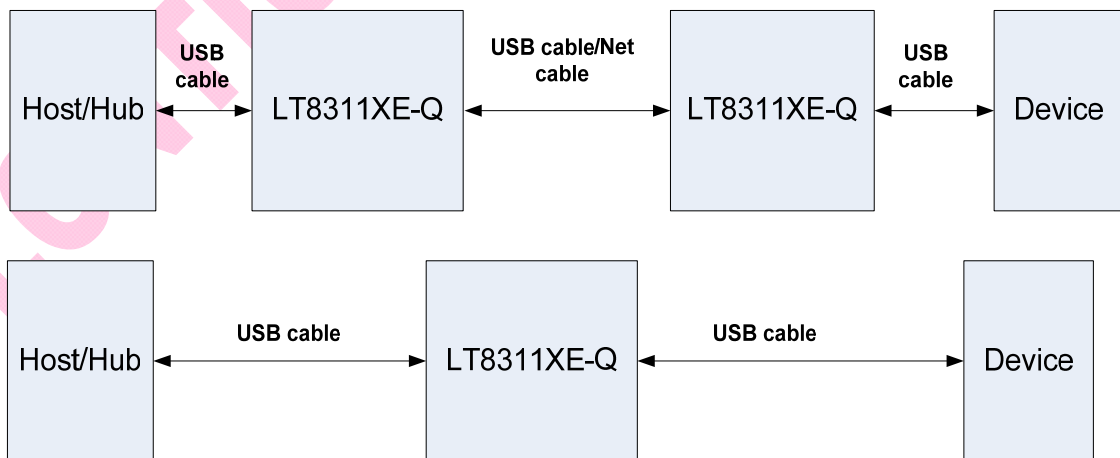

Figure 1. Application Diagram

4. Ordering Information

Part Number	Operating Temperature Range	Package	Packing Method
LT8311XE-Q	-40°C to+85°C	QFN16 4*4	Tray

LONTIUM CONFIDENTIAL

Copyright © 2017-2019 Lontium Semiconductor Corporation, All rights reserved.

Lontium Semiconductor Proprietary & Confidential

This document and the information it contains belong to Lontium Semiconductor. Any review, use, dissemination, distribution or copying of this document or its information outside the scope of a signed agreement with Lontium is strictly prohibited.

LONTIUM DISCLAIMS ALL WARRANTIES, EXPRESSED OR IMPLIED, INCLUDING THOSE OF NONINFRINGEMENT, MERCHANTABILITY, TITLE AND FITNESS FOR A PARTICULAR PURPOSE. CUSTOMERS EXPRESSLY ASSUME THEIR OWN RISK IN RELYING ON THIS DOCUMENT.

LONTIUM PRODUCTS ARE NOT DESIGNED OR INTENDED FOR USE IN LIFE SUPPORT APPLIANCES, DEVICES OR SYSTEMS WHERE A MALFUNCTION OF A LONTIUM DEVICE COULD RESULT IN A PERSONAL INJURY OR LOSS OF LIFE.

Lontium assumes no responsibility for any errors in this document, and makes no commitment to update the information contained herein. Lontium reserves the right to change or discontinue this document and the products it describes at any time, without notice. Other than as set forth in a separate, signed, written agreement, Lontium grants the user of this document no right, title or interest in the document, the information it contains or the intellectual property it embodies.

Trademarks

Lontium™ 龙迅™ and ClearEdge™ is a registered trademark of Lontium Semiconductor. All Other brand names, product names, trademarks, and registered trademarks contained herein are the property of their respective owners.

Visit our corporate web page at: www.lontiumsemi.com

Technical support: support@lontium.com

Sales: sales@lontium.com